



AURORA

IMAGINING
WATER

PUBLICATION ONE

This publication is conceptualised and made by Quicksand, an India-based research and design agency and collaborating artists on *Aurora*. *Aurora* is an artistic experience around water and will run from 19 September to 7 October 2018 at the Toxteth Reservoir in Liverpool. This is the first in a series of publications that accompanies it. Through these, we hope to

bring together stories from Toxteth as well as stories of water from around the world. Our perceptions of water may vary, but the connection we have with it is essential to who we are as human beings. We hope to share that through these stories as well as the collaborative journey of creating *Aurora*.

WHAT IS AURORA?

Aurora is a new work of art, an experience, created especially for Toxteth Reservoir.

It is all about water. The Toxteth Reservoir used to hold over 2 million gallons of it and now sits empty. For three weeks in

September 2018, we are going to fill it with water, ice, lights, sound and create a totally unique type of experience that will feel like walking through a waking dream about water.

Why water? For so many reasons.

For one, water is incredibly precious; we have the luxury of never having to think about that too much and drink clean water straight from the tap, but that doesn't mean that as a resource worldwide it isn't a terribly fragile thing. In some places there is too little, in others too much and sadly in too many places it is too dirty, and even for us here there isn't as much of it as we think there is. But all life flows from water, we are literally made up of it, we need it not just to drink to but to grow food, to make things that we use – from mobile phones to the paper this is printed on. It is more important and precious than oil or gold, but we never think of it that way.

So why make a piece of art about it? Well, *Aurora* is about trying to get us thinking differently about water, to try and turn it into something precious, like a jewel, to create a beautiful hypnotic experience that brings us as audiences closer to water and allows us to interact with this substance that we take for granted with a newfound sense of wonder.

This is the first of a series of free publications following the story of how we are making *Aurora*, the stories around it, the people involved and the relationship between the area, the city and our global water reserves. *Aurora* is a huge project made by artists from all over the world, telling a global story full of legends, innovation, beauty, technology and hopefully full of future. These publications will track this journey and is an invitation to be part of it, no matter where you are reading it.

Ben Eaton
Technical Director, Invisible Flock



The testing of *Aurora* in the Toxteth Reservoir dispels some of the soothing, meditative darkness.

LISTENING TO THE CATALYSTS

We spoke with both the artists and curators of *Aurora* to understand more about the artistic intent of the work, their own expressions and relationship with the theme of water and how this can be brought forward to various audiences. Over a series of written pieces, we will explore various aspects of these explorations, reflecting upon emergent outcomes of the work and the process of making it.

We want to make water more visible – as a resource, as a part of the larger cycle, because it is hard for us to imagine water outside of the fact that it is something we need, to consume, to live. We want to create something beautiful around water. With this work, the question was around looking beyond the classic narratives around the environment, to think about water as this complex element of value. About humankind’s innate and spiritual connection with water.

Clearly, humans are able to live in habitats and environments that are far from ideal. So scaring people about a terrible future isn’t going to work. We need to understand the larger value and through that value, we would be able to understand the effects. We have to have this conversation, but the work is about presenting a different approach to this. About reminding people about the magic of water. And realistically for them to be able to engage fully with the work, they will need to understand the larger context as well. The experience itself might be very beautiful but in order to join the final dots, we might need to get them some more contextualising material. But the idea that this work is trying to approach, present or talk about is different, because it’s art and not documentary.

Fiction will really help us, help us approach it not as a series of information but in a way that looks at stories. Because we can

all relate to stories. The utilitarian, rational response would be that we are running out of water. But there is no language for this other thing we are talking about. Maybe spiritual is the best we can come up with. Or alchemy. Otherwise it always goes back to the utilitarian value. But that is clearly not working, as people aren’t connecting. So how do we have this other conversation?

The point of this work is not just to preach to you about something, but to move beyond reason and logic to engage with the more sensual and emotional parts of us and perhaps through that approach, have a deeper conversation.

—
Victoria Pratt, *Creative Director*
& Ben Eaton, *Technical Director*,
Invisible Flock



“Gotong royong” – (collaborative working) and “Oprek” – (making something from anything) are terms, Invisible Flock and myself learned collaborating on a Hackathon in Indonesia. Sustainability, water and coastlines became our subjects to be re-imagined in one of our most ambitious projects set in Toxteth Reservoir, a container for 2 million gallons of clean water for a burgeoning population of Irish refugees built in the 1840s. FACT aims to work with new communities and this collaboration with Invisible Flock and Liverpool City Council brings our aims to life.

—
Mike Stubbs,
Director, FACT

Aurora brings together a lot of things core to FACT’s practice – it unites an ambitious artistic programme with exceptional collaborations, community engagement and a focus on audiences. We wanted to present something spectacular which feels very connected to the locale: something which could only happen here, in Liverpool – but which is also very international in its approach. FACT has a very keen sense of place and position, and feels very rooted to the city, but is also very outward looking and international: something which the development of this work reflects. In bringing these different perspectives together, story-telling

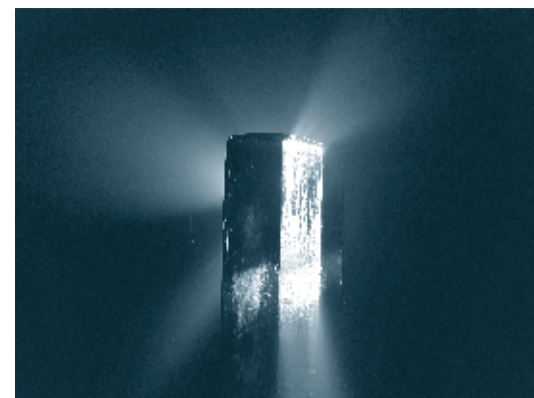

becomes an invaluable tool for sharing and understanding. We use fiction to understand, and create our realities and to question the world around us. It is so easy to understand the importance of the stories we tell to one another, or the stories we make together. In recent years, FACT’s programme has been concerned with the ways in which art (as a mode of storytelling, or creative fiction) is able to truly tackle the contemporary moment: the issues and disappointments, as well as the joys, of our shared contemporary imagination.

Talking about universal themes like climate change, and more specifically water (something which people rely on every day), is core to the approach of FACT’s programme. We want to take these topics and begin to unpack them, in a genuine way which allows for many possible levels of engagement. Something like water, which is both conceptually abstract for most of us and terrifyingly concrete for others, is at once difficult and simple to grasp. *Aurora* focuses on water: on its importance, scarcity and excess. It is the perfect, elemental example of something which we may not fully understand, but with which we have a very specific (geographically dependent) relationship: one which ranges from the political and spiritual, to the practical. Amongst innumerable other things, water can be a basic fact of life, a god, a tool for either unification or division, or a physical threat. Understanding that something so seemingly straightforward can actually be so multi-faceted is a very powerful moment. In focusing on the most elemental force of our existence, *Aurora* is able to move between these two realms: politics and poetry, beauty and fear.

—
Lesley Taker,
Producer/Curator, FACT

MAPPING THE PEOPLE

Here is the first of a series of maps presenting the stakeholders and people collaborating to make the project. As the months progress this map will build and grow with each individual who connects with the work.





*The smallest number of water molecules required to form an ice crystal is 123



A DIARY ENTRY

**Workshopping
and making music
with children**

The soundscape for *Aurora* tracks the water cycle from the melting of glaciers in the summer and the breaking of the monsoons through to the refreezing of the glaciers in winter. Using water to compose with as an instrument, we have worked with four schools to build a unique sound composition, which will be performed and recorded on 6th July.

I enjoyed playing and experimenting with new instruments I have not used.

We are doing this to spread awareness about a real in water.



What did you do today?

We played a musical instrument but, the instrument was water.

We sang a song that I really like.

Also we made a bunch of music out of water.

We made music out of ice and water and found special and water found something that not you just drink.

I enjoyed the part when everyone worked together to make one sound to a video.

We did this to show water is amazing and to make people more aware of it and stop taking water for granted.

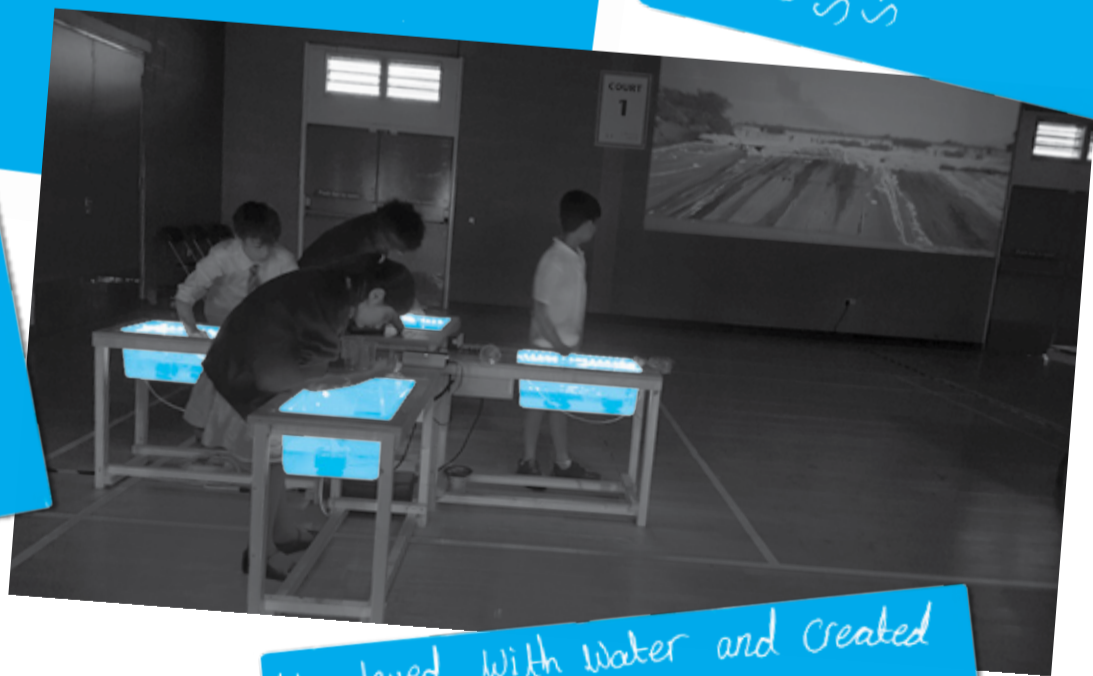

My partner's part was the ice block.

We are here to tell other that water is good.

We played with water and created music.

We did this to show people that water is an amazing thing.

INTERLUDE WE ARE WATER

The journey of water to
the city of Bangalore, India

Quicksand



Arkavati, a tributary of the mighty Cauvery



Irrigation channels fed by the river



The Kanva Reservoir



Cauvery Supply lines to Bangalore



A storage tank in Bangalore built and used by public works

Automated water pumps in the same residence

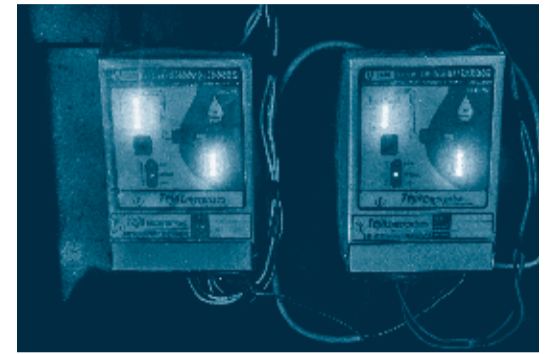

A water sump in a private residence in Bangalore

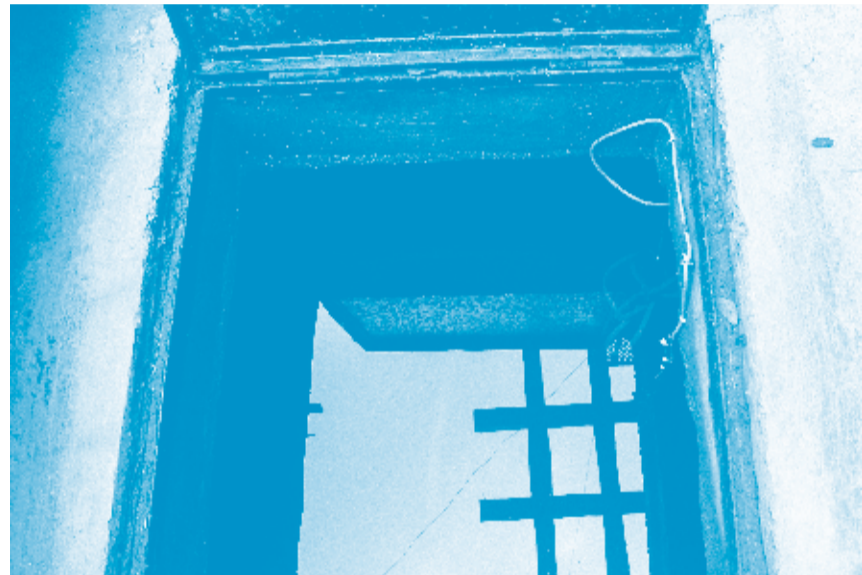

Overhead water tanks in a Bangalore neighbourhood



A water tank connected to a borewell

An obsolete manual borewell pump



When the Cauvery doesn't co-operate



A Private water supply tanker



So what will it be today...?



Drink, wash up, cook your food and go for a swim

IMPULSE RESPONSE

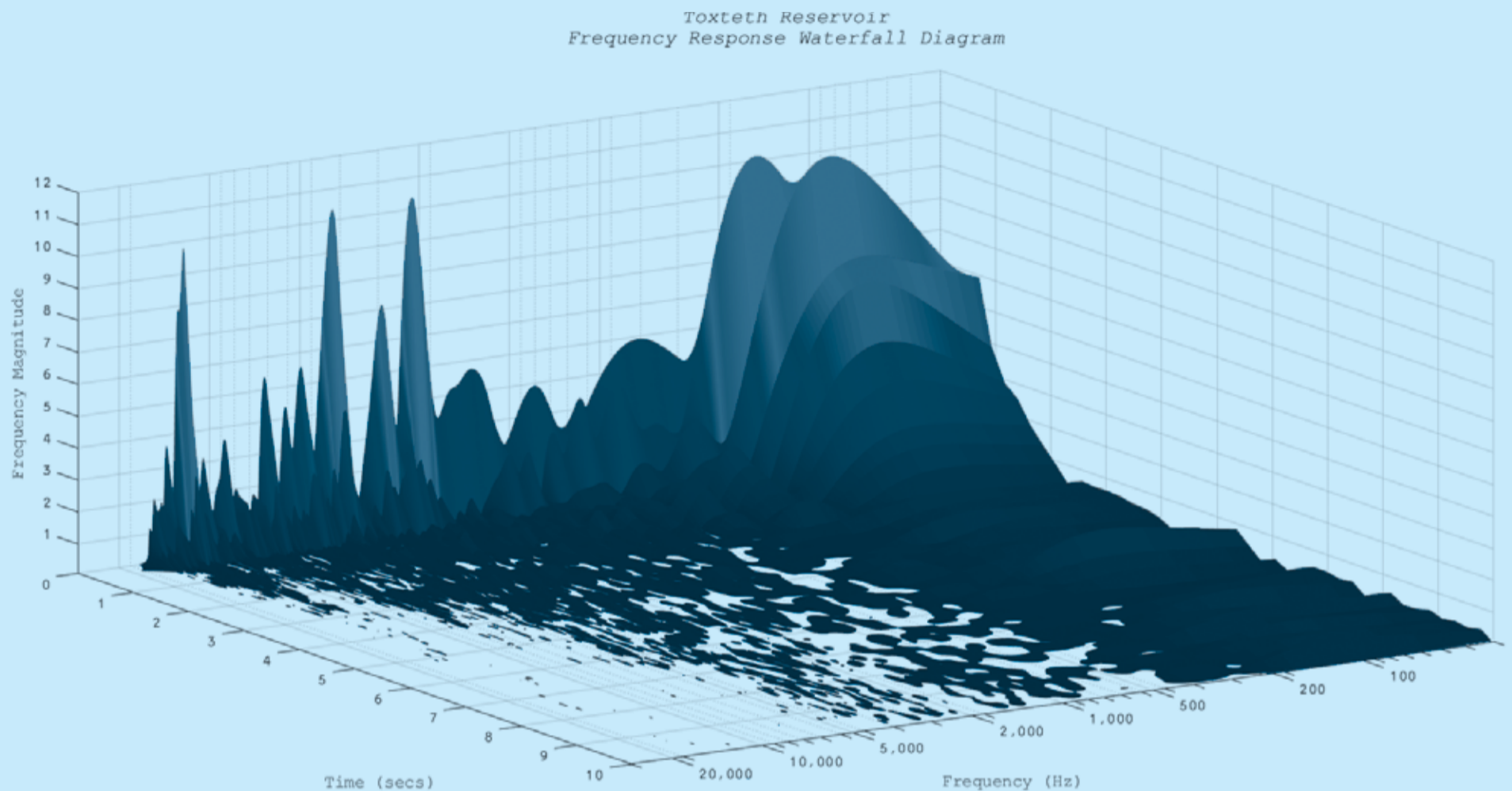

Stuart Mellor
Creative Technologist, Invisible Flock

The 3D waterfall diagram is a representation of the frequency-time content of the gathered Room Impulse Response, recorded at Toxteth Reservoir.

The measurement, taken from the centre of the space, captures the character and rate at which sound energy dissipates within the space. As can be seen in the diagram (looking at the bottom two axes, labelled Time and Frequency), the decay time is roughly 10 seconds.

Using a waterfall diagram, it is possible to determine how the decay pattern occurs within different frequency bands and can be distinguished by longer and more pronounced peaks. As such, it is clear in this diagram that there is a distinct low end sustain, around 20 Hz to 500 Hz, which makes

up largely what we hear. It is interesting in this case, however, that the mid-top end, 500 Hz – 5 kHz still maintains a lot of energy with a fair amount of fluctuation, seen as small and aperiodic bumps.

This illustrates a high amount of diffusion, or highly complex reflection patterns, thus matching the more diffuse character that is audible in the space. In other words, sounds travelling from a source are less likely to echo and are more likely to dissipate in an evenly distributed pattern. This is likely to arise from the slightly banked archways surrounding the space, the arched ceiling and the irregularly shaped, rough stone blocks used to construct the building.

ICE, LASERS AND WINCHES

Experimentation – failures, successes and waiting
for the ice block to come crashing down.
A short story about those who do the heavy lifting.

Miebi Sikoki
Systems Architect,
Digital Nativ
Collaborating Artist,
Aurora



A *winch* is a mechanical device that is used to pull in (wind up) or let out (wind out) or otherwise adjust the “tension” of a rope or wire rope (also called “cable” or “wire cable”).

Demo mode is short for demonstration mode, and is a feature that is often found in consumer electronics. The main purpose of the demo mode is to demonstrate the features that the device has.

A computer's *factory settings* are those which the computer had when it was first purchased from the manufacturer.

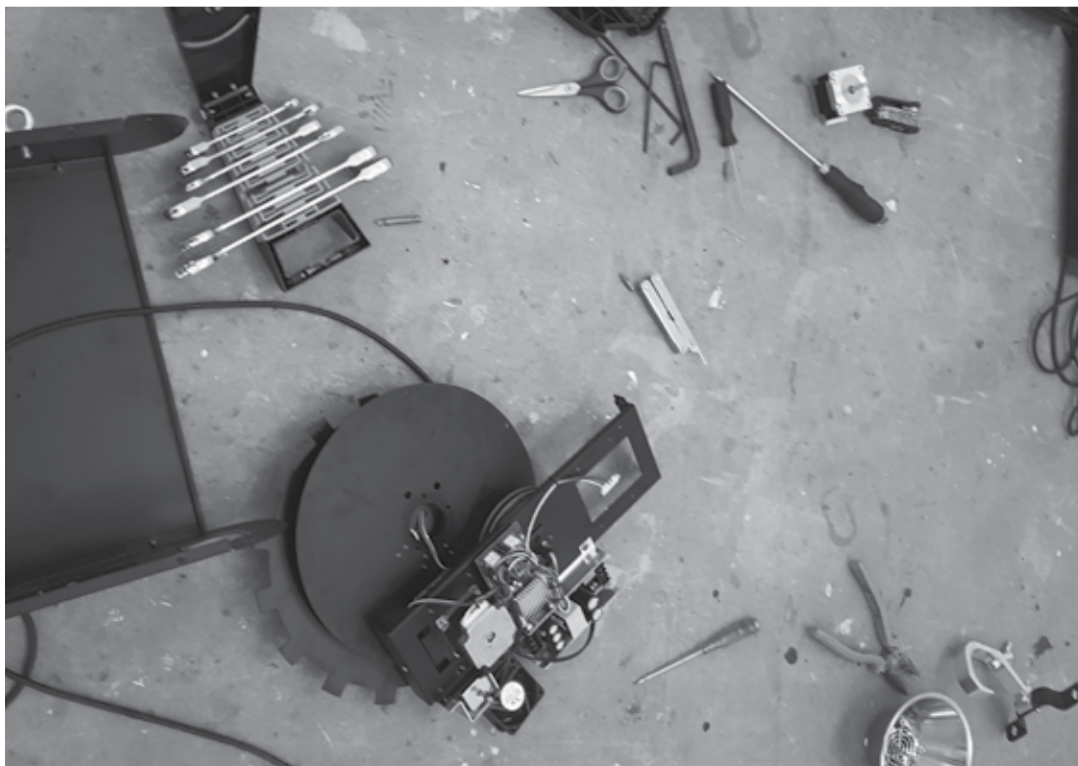

Franken Winch

Born out of necessity, Frank is one of 40 winches built for *Aurora*. A kinetic stage light was used to test the idea of suspending blocks of ice around the space and control their positions remotely. Designed to carry an LED Light and Plastic Cover, the winch that came with the unit had a maximum lift capacity of 4kgs. We needed something stronger, something that could lift 10–15kgs.

The idea to modify the winches came when one of the units got stuck in demo mode forcing us to take it apart to see what was wrong. It turned out to be a loose connector but from that experience we learned about the inner workings of the winch and soon started thinking of ways to modify it to carry heavier loads. Smaller drive pulleys, stronger motors and reduction gearboxes were all explored in an attempt to increase its lifting capacity without disrupting the factory settings. To the machine, it had to seem like nothing happened.

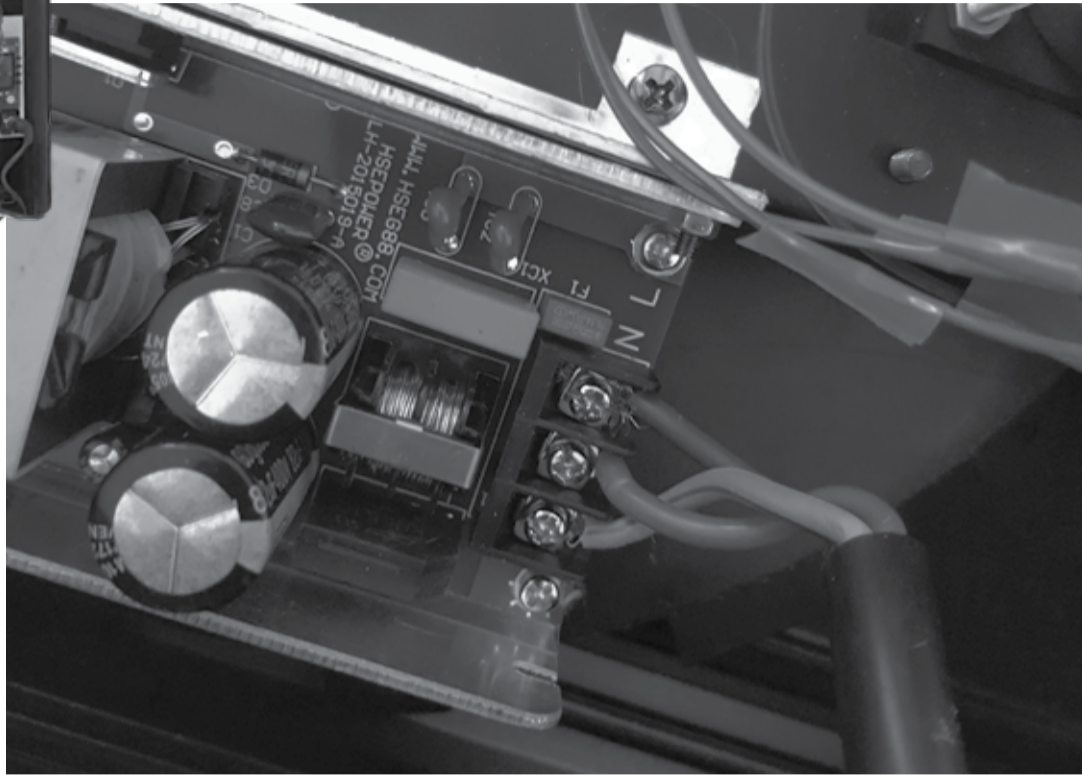

4:1 Ratio reduction gearboxes were added to the front shaft of each of the two drive motors and fitted back on the frame. The device powered up, but because the rotary encoder (a rotational counter for tracking speed, distance and position) was spinning 4 times slower than normal, it caused the software to crash and enter safe mode.

Our response to the problem was to mount the rotary encoder to the back shaft of the motor to keep it spinning at the original speed before the addition of the gearbox.

On site testing proved that the winch could safely lift a 12 kg block of ice. A problem that seemed to creep up during testing was the occasional sound of the drive belt skipping a tooth. This was most likely due to minor errors in the 3D printed drive pulleys designed to fit the new gearbox shafts. Our response to the problem was to mount the rotary encoder to the back shaft of the motor to keep it spinning at the original speed before the addition of the gearbox.

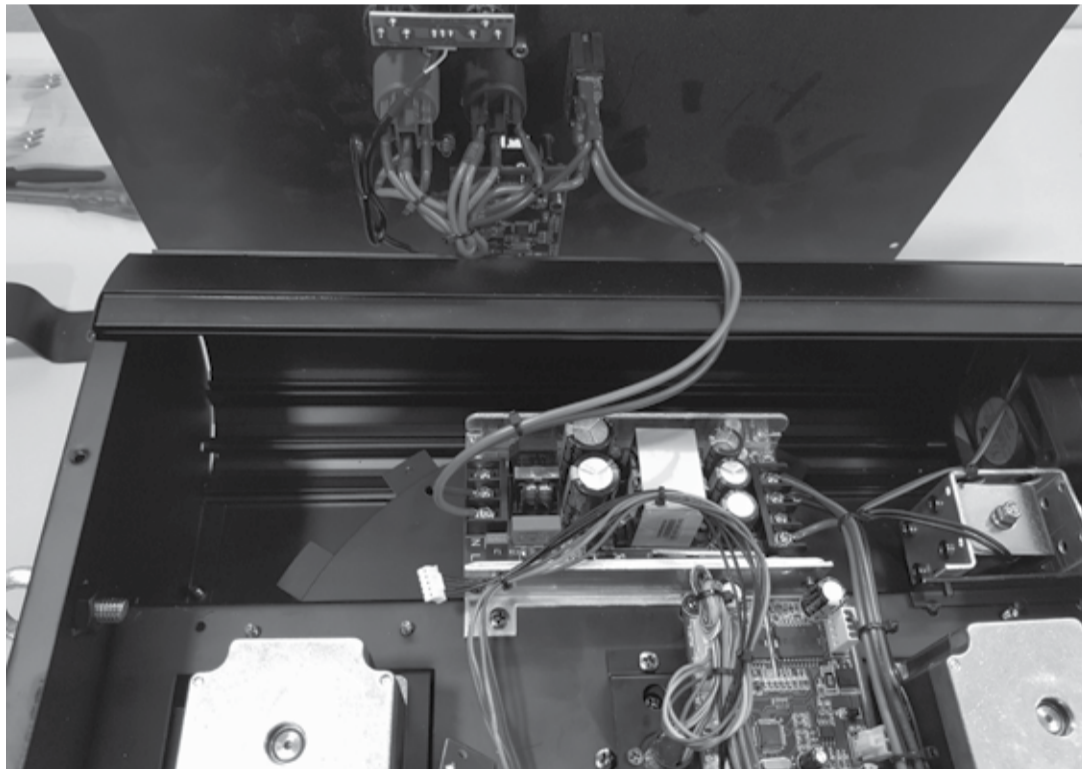

A reduction gearbox is a mechanical device to shift rotational speed.

A drive pulley is a pulley that applies force to the belt, cable, chain, etc. to drive the system it's attached to. A shaft connects the pulley to an engine or motor. A drive pulley drives the system it's attached to.

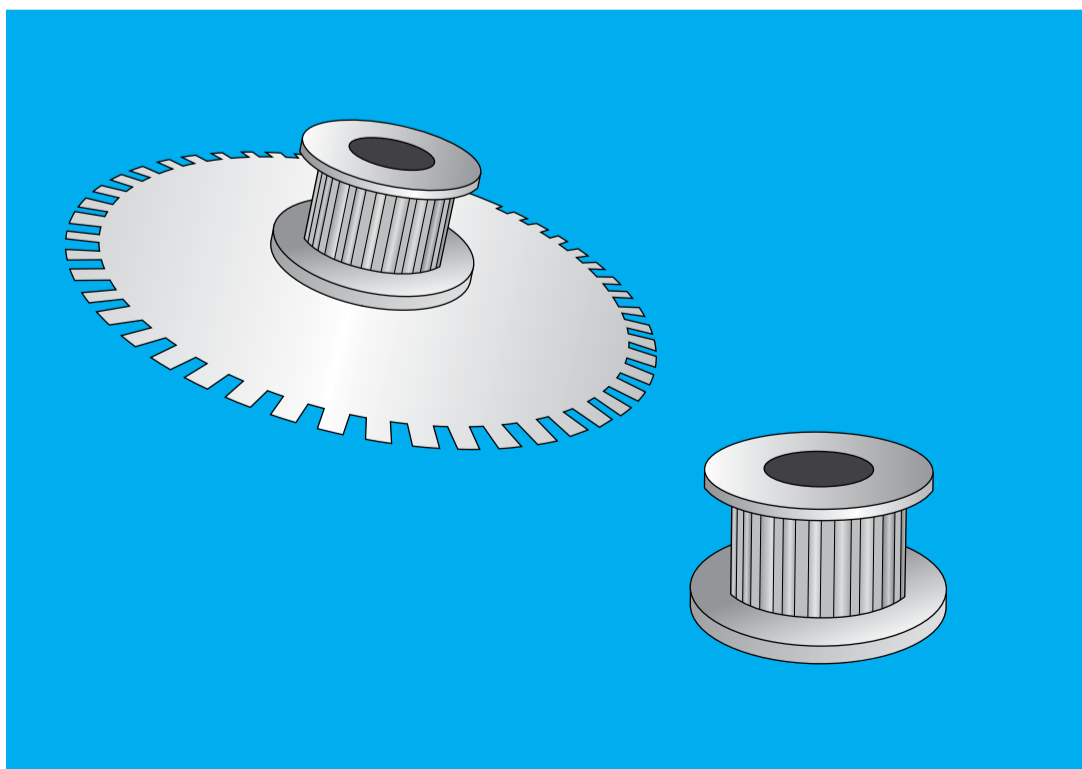

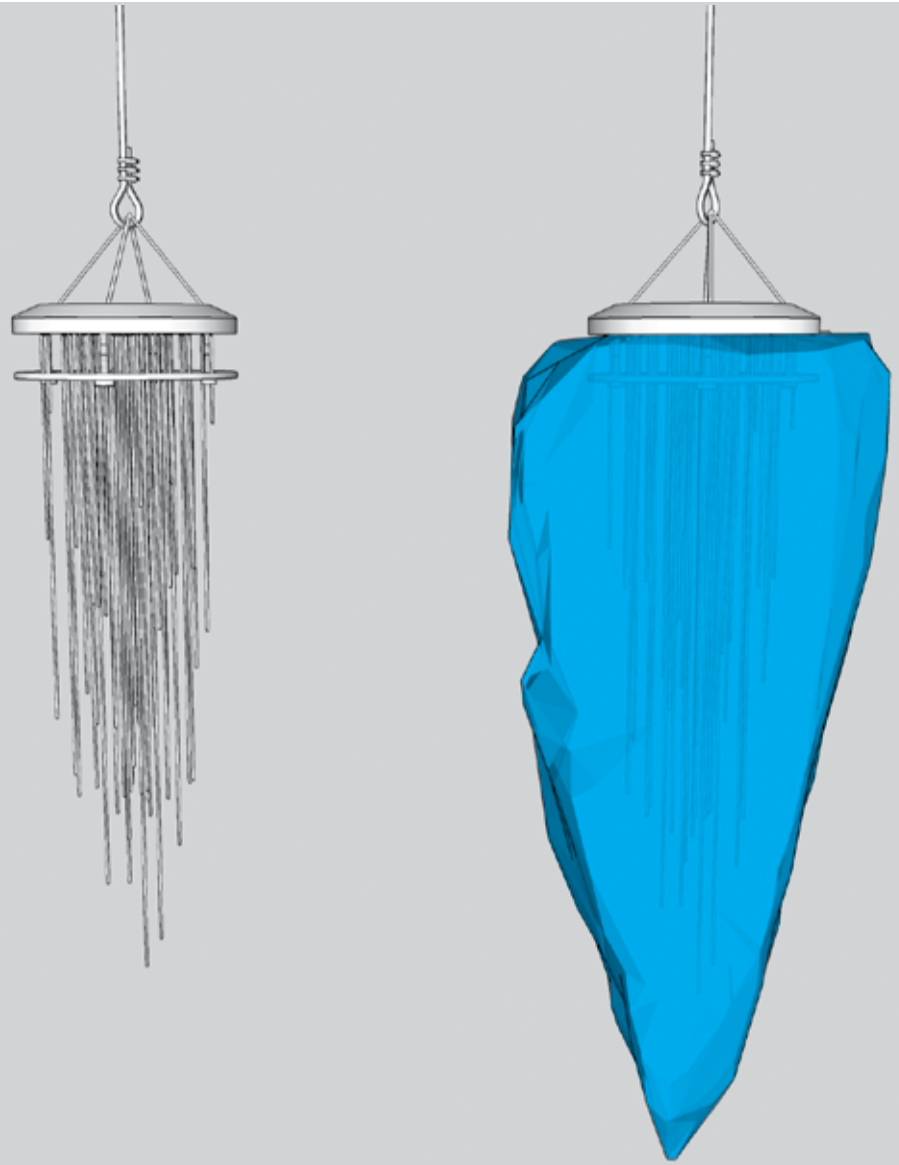

Tech Effect

Tech influences the experience of *Aurora* subliminally. It isn't seen or heard, but what it instruments is felt. It is the impetus of stimuli. Like the lifeblood of our bodies, tech is 64, 73, 79, 83% fine tuned to functions of a greater whole; the sight of controlled water levels seep under the skin, lasers pierce the pulse of steps, echoes off icy refractions chill the bones. Tech orchestrates each sense to be at once immersed in perceptual isolation and heightened holistically to an inherent, ancient wonder just beyond the grasp of scientific, dogmatic understanding.

Formatting Awe

Water resonates. In creating an immersive, confined, expansive environment, the material dissolves, we shed the sense of time, and instance. The space becomes infinite and primordial. It triggers possible memories of water as a conduit for consciousness.

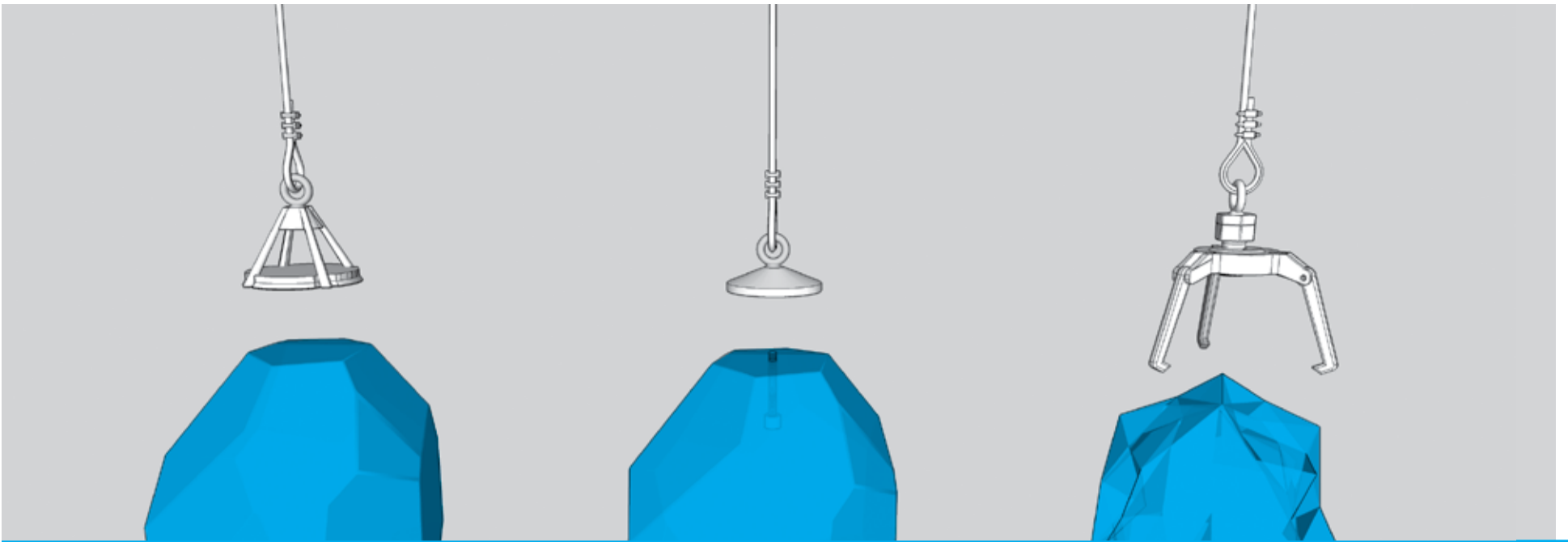

Cups and cones and claws oh my..



COMISTON SPRINGS

The moubray, peewit,
sandglass and fox

Text: Rob St John
Illustration: Tommy Perman

On the southern edge of Edinburgh there is a collection of non-descript stone buildings dotted through the city's suburban sprawl: each taken over by the creep of nature to one extent or another; each teetering on the edge of ruin. Put your head to the black iron door of the largest building, next to a series of firm diagonal marks in the stone, and you hear water. Anonymous, unseen water tapped from underground springs: water on which Edinburgh was built.

In 1674, a Dutch engineer Peter Brusci was commissioned a fee of £2,900 to bring piped water to Edinburgh from springs at Comiston, to the south of the city. In 1681, the 'sweet water' from the Comiston Springs was routed through wooden pipes into a series of city centre wells. There were five springs at Comiston, feeding a lead-lined tank in a stone water house. Up until the 1960s, the tank was presided over by four lead figures of animals: a hare (or moubray as its spring is named), a lapwing (or peewit), a swan (or sandglass) and a fox, all thought to date from the water house's 17th century construction. In a 2002 paper on the Comiston Springs, architectural historian Richard Emerson suggests that a fifth lead animal, an owl, is missing from this peculiar assemblage. Emerson suggests that this odd collection of – swan apart – land and air dwelling creatures was the product of Brusci's notion of the grotto as a place of natural mystery and wonder: a liminal zone between the terrestrial and the subterranean; the real and the imagined.

The Comiston Springs water house and seven stone wellheads now sit partially derelict, overgrown and unmarked at the edge of Edinburgh's southerly creep. Increasing demands for water from the growing city led to new springs being

sourced at Swanston in the early 1700s and subsequently through the construction of reservoirs in the Pentland Hills following the formation of the Edinburgh Water Company in 1819. The lead animals are gone now, housed in a glass case in the Museum of Edinburgh. Nettles and brambles tangle around metal barriers at half-mast, half-heartedly keeping an absent audience at bay. Sharp edged mason's marks cut at angles into the dressed stone echo runic symbols.

The Comiston water houses' neglect is acute: the Buildings at Risk register for Scotland list the buildings as 'at risk', yet there are no plans to restore or celebrate the site. A historically important set of buildings rich with stories are left to ruin, whilst the centre of Edinburgh continues to remake notions of its own heritage. Debates over the conservation of these buildings has parallels with those over biodiversity conservation: how do we prioritise what to conserve and restore, and why? The history of water in Edinburgh is largely forgotten here, yet for now, the sound of the springs still rings unseen around the disused water house and well heads.

THE SCALE OF THE RAIN

James Hamilton
Composer, Collaborating Artist, Aurora

Generally when I'm writing I start at the piano. The romantic stories of flashes of inspiration coming to composers in the shower, driving their car or waking in the middle of the night seem reserved for the John Williams' and Hans Zimmers of this world.

99% of my music starts sat in my writing room in front of a piano and a computer. This is where ideas are mined, shaped, developed, nurtured and often chucked in the bin. The music for *Aurora* started in much the same way. I read the brief, tried to figure out the narrative or the point of the work and threw my fingers at the keyboard.

Some music happened.

Job done.

A few weeks later I got to visit the reservoir for the first time. From the instant we walked in I knew I'd be scrapping everything I'd written so far.

The sound in the reservoir is like no other space I've been in. A huge stone built structure half the size of a football pitch with several brick arches in the roof. From the look of it, when you shout you'd expect to hear an echo of your voice repeating back at you, like in a cave. Instead you get a continuous, smooth, almost endless trail of sound that moves around the room. You can almost trace it's path as it floats through the arches of the reservoir, a ghost of it's source. It's difficult to describe but if I had to put it in words I'd say it's cinematic, it sounds like the future.

One of the cool musical tricks you can perform in the space is to create harmony with yourself. You sing or play a note and then before the sound disappears add other notes on top of it. I spent a good twenty minutes doing that without getting bored. It soon became very clear that the music had to work with the unique sonics of the reservoir. It meant thinking about the music creation in a totally new way, I couldn't just chuck out any old nonsense, I had to play with the room. The reservoir has become a partner in the compositional process, an instrument in itself.

With *Aurora* we wanted to make an installation built out of and inspired by water and the music and sound needed to reflect that. We wanted to look into how we can create music from water, can it be used as a sound source and incorporated into the piece? We tested hydrophones (underwater microphones), hydrolophones (a musical instrument that vibrates water to create sound) and using large blocks of ice as percussion instruments. One thing that stood out to me was the discovery of a rare Indian melodic percussion instrument called Jal Tarang. Jal Tarang is a set of metal or ceramic bowls hit with a small beater and tuned to a scale using varying amounts of water in each bowl. Further investigation revealed a scale from Indian classical music that was traditionally used to call the monsoons. These elements became the building blocks for the music for *Aurora*. Coupled with underwater field recordings from glaciers, reservoirs and flood plains of India, it gave us our sonic pallet for the installation.

In the build up to the installation we are working with sixty students from four local schools to give them the opportunity to respond to some of today's issues surrounding water. These students will be using the same building blocks we have to present a short performance in the space. Unique water instruments have been created that they will be playing on the day and recordings from the workshops and performance will be used in the final installation.

Aurora Theme

James Hamilton

$\bullet = 56$

Score for Aurora Theme, measures 1-6. The score includes parts for Voice, Violin 1, Violin 2, Viola, and Violoncello. The key signature is B-flat major (two flats) and the time signature is 2/4. The lyrics are: Ni da sa ni pa ni da ma ga ga re.

Measures 1-6:

- Measure 1: Ni
- Measure 2: da
- Measure 3: sa
- Measure 4: ni
- Measure 5: pa
- Measure 6: ni

Measures 7-12:

- Measure 7: da
- Measure 8: ma
- Measure 9: ga
- Measure 10: ga
- Measure 11: re
- Measure 12: re

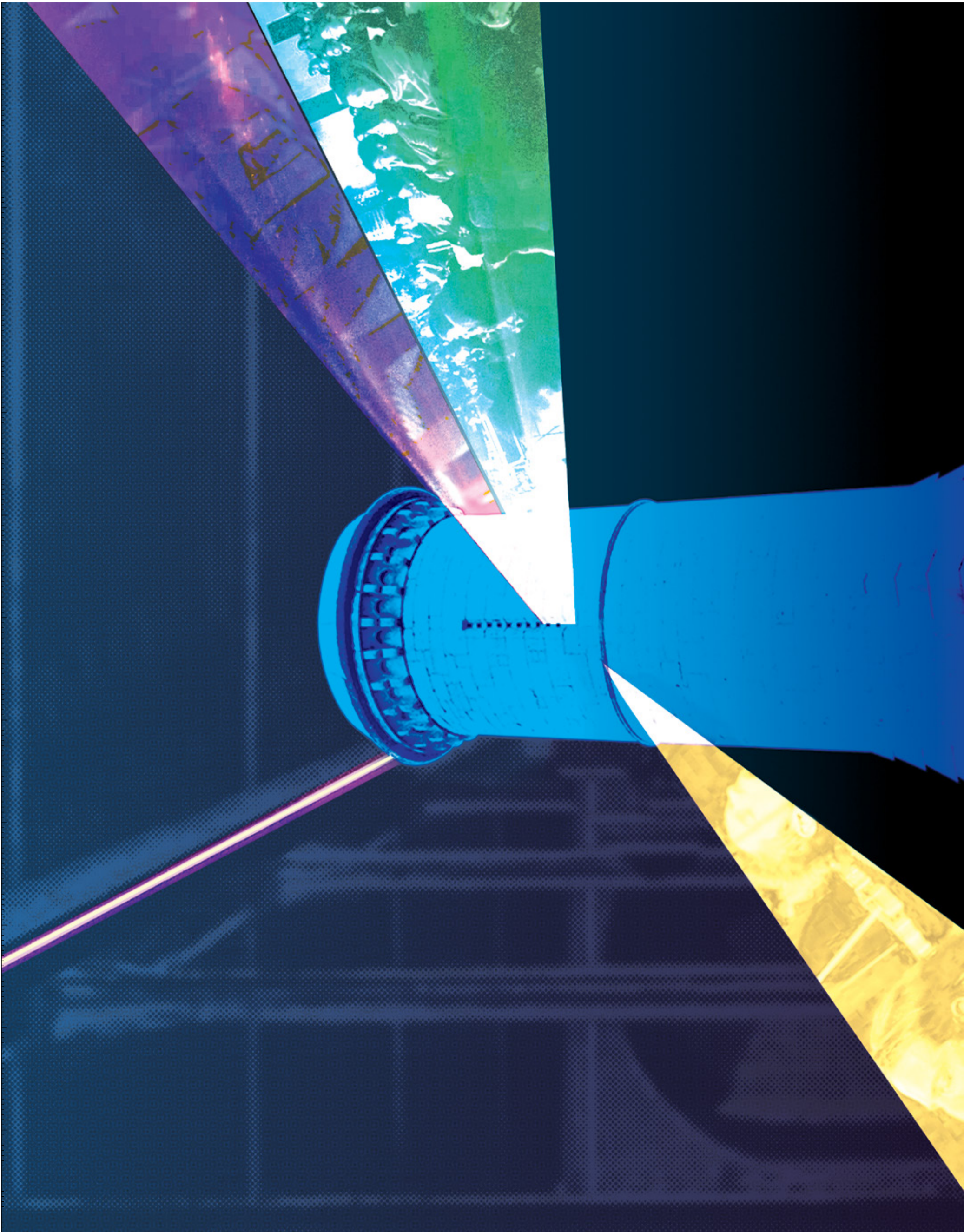

AURORA & ARRIVAL CITY

SUMMER SOCIAL

Friday 6 July, 7–9:30pm
Toxteth Town Hall
Free

In conjunction with Festival 31, we will bring *Aurora* and *Arrival City* to Toxteth's Town Hall.

Arrival City is a project running in parallel with *Aurora*, presenting a portrait of Liverpool, and more specifically Toxteth, as a city of migration.

We are inviting the residents of Toxteth to come and participate in an open discussion, in response to a lineup of poets, rappers and musicians offering their viewpoint through their words and sounds: challenging attendees to think about Toxteth's history, and celebrating their vision of the future.

Alongside, Invisible Flock will present an interactive mini maker-faire showcasing some elements of the art and technology that will feature in *Aurora*, offering a chance to playfully explore the themes behind the project ahead of the launch in September.

Spaces to the Summer Social are limited. For more information on how to get involved in the public event in July, or about the opening in September, check fact.co.uk/aurora or call 0151 707 4444.

Aurora is commissioned by FACT, in partnership with Liverpool City Council, Invisible Flock and Dingle 2000. Supported using public funding by the National Lottery through Arts Council England; and British Council. *Arrival City* is supported by Goethe-Institut. The Summer Social is part of Festival 31.



IMAGINING WATER

**Water transforms land into
something mysterious.
What hides in the depths?
Does it not make one curious?**

Quicksand







A body of water is *attraction*.
A voluminous incomprehensible force.

Some know... more than you or me.



Surrender. Patiently wait and then dive!

Wade into it







Find something memorable



But be careful!









Think about it. Make your plans. Learn from others.



Throw caution to the winds







What did you leave behind?

REJUVENATOR

A short story | Part 1

Bharat Mirle

“You see all that?” Mr. Patel pointed at the horizon, “if you climb up, you will be able to take a photo...” he continued, signalling to a cluster of boulders that stood precariously on the edge of the hillside.

I obligingly hoisted myself to the top of the rocks. Below, the valley lay sprawling, its lush green thicket stretching as far as the eye could see. Combined with the crimson smears of the setting sun across the almost-clear sky, it was a sight to behold. I turned around to check on Bejoy, my photographer. From prior experience, I knew that his rotund physique was not suited to strenuous activity and I grew concerned as to how I would get him to climb up. But it seemed that he had already found a way out of this predicament.

“No light...” muttered Bejoy, casually peering through the viewfinder of his camera, ignoring the look of bewilderment on Mr. Patel’s face, “Shoot tomorrow...”

As we made our way down the hill, back to where the taxi was parked, I tried to liven the mood with a pep-talk, “Mr. Patel, the Hospitality industry is highly competitive, so we really need to find a distinct way of portraying ourselves...and we can only do this if we capture the true essence of this place. For that we have to experience it...and right now, we haven’t even seen it yet... But to really capture the soul of the place, one has to experience it...”

Mr. Patel looked at me and frowned thoughtfully, bobbing his head lightly. “Yes, absolutely. The brochure must really capture the soul of this place...”

Bejoy rolled his eyes, while surreptitiously playing a game on his phone. He had heard many variations of this conversation before. “Yes...” I went on, “We really need to capture what is truly unique about it...”

“Oh that’s easy...,” Mr. Patel quipped, “It’s the rejuvenation zone”

We had been on the road since the break of dawn and it was the fifth ‘scenic spot’ at which Mr. Patel had made the driver stop. “These are Chairman sir’s favourite photo locations.”

Mr. Patel seemed nervous and with good reason. Though it was not at the physical scale of the apartment complexes or townships that his company generally built, Secret Springs Luxury Resort & Spa was ambitious in its own way. The personal passion project of the Chairman himself, the property was an old estate that he had inherited from an estranged uncle. Inspiration struck him

when he discovered a natural spring on the land. Convinced that the water from this spring had miraculous healing powers, he had begun developing the place into an exclusive retreat for ‘like minded people’. Few from his company were privy to its details and Mr. Patel considered it an honour to be one of them. Development of the property had already begun and his first order of business was to get a brochure made in order to attract investors.

The estate was not far away, but the road we took was tightly wound around the hill and climbing up slowed us considerably. By the time we got there, it was dark. The first glimpse of the estate was a security guard’s cabin, lit by a solitary bulb, hanging limply in the blackness. It was only once we got closer that I noticed the fence behind it, stretching on either side. The guard exchanged looks with Mr. Patel, hurriedly opened the gate and we took off into the dark. “One of the first things Chairman sir did was put up this fence...his uncle used to let all sorts of people inside...you know, some of the local people would come and spend hours together...no privacy at all...”

We drove for several minutes. Except for the little patch of asphalt that caught the car’s headlamp, everything else was plunged in darkness. After some time, lights appeared in the distance and as we got closer, I realized it was a large, colonial style bungalow. However, except for the porch light and a couple of others on the side of the house, there were no other lights and the house lay shrouded in darkness. There appeared to be some construction material piled in a corner, but it was difficult to see what exactly it was. Surprisingly, the car did not stop at the house and we drove past it, taking a dirt path that led into the bushes.

“Whose house?” Bejoy looked a little worried.

“That is where Chairman sir’s uncle lived...currently it is being renovated... You will see tomorrow...Mr. Chairman will meet you there...” Mr. Patel smiled.

“Tonight sleeping?” Bejoy made no attempts to hide his uneasiness.

“Just you see...” Mr. Patel’s smile grew wider.

After some time, the car came to a halt and the three of us got out. It was still too dark to see, but before we could ask him any more questions, Mr. Patel pulled out a flashlight from his pocket and set off down a narrow path, forcing us to hurry after him.

After walking a short distance, he stopped in his tracks, shone his flashlight into a bush and peered at something before turning, “It’s here... come on...”

Hidden behind a thick clump of bamboo was a contemporary-looking door. It was equipped with some kind of scanner that he flashed his official ID card into, before punching a few keys on a number pad below. The door unlocked and Mr. Patel ushered us in. We were immediately enveloped by a curious odor, one I could not place immediately, but there was a freshness to it. However, it was still too dark to see anything and we just stood there for a few moments. I could hear Bejoy curiously sniffing the air, “some smell...” he muttered, but was cut short by Mr. Patel, “Behold!” he shouted, “The rejuvenation zone!”

The lights in the room turned on with a flash, revealing what appeared to be a huge swimming pool. However, we soon realized that its size was merely an illusion. The walls and the ceiling were fitted with mirrors, making it look much bigger than it was. In actuality, it was no larger than the average sized children’s pool. We stared at it in silence for a few moments, until Bejoy suddenly blurted out, “That’s all?”

Mr. Patel was stunned, “That’s all? My dear fellow...” he began, but then changed his mind, “Ah...you think this is just an ordinary pool? Let me tell you, this is natural spring water...in this region, it is unheard of... can you smell that? The water is completely loaded with rejuvenating minerals...sulphur and... and... other...minerals as well.” As Mr. Patel tried to win Bejoy’s approval, I took a closer look at the pool and realised that the water was turbid and did not look particularly clean. I was about to point it out to Mr. Patel, but just as I turned to do so, I saw Bejoy bending down and splashing some of the water onto his face.

“How does that feel?” Mr. Patel beamed at Bejoy.

“Nice...”

“You know, Mr. Chairman has told me personally, if he does not take a dip at least once a day, then his entire energy feels drained. He needs it!”

Bejoy nodded at him silently for a few moments.

“Dinner?” he asked.

To be continued

MYTHS OF WATER

Bharat Mirle

Water surrounds us in more ways than we can possibly know. Not merely in a physical sense, but also in the way we think, perceive and even believe. The mysterious allure of water is something that mankind has grappled with for centuries and this is evident from our mythology and folklore. Across geographies and cultures, it has repeatedly provoked the imagination, birthing some of the most curious beings in recorded history. Despite the world's diversity, it would be a challenge to find even one community that has not fallen under the sacred charm of water. Spirits, demons, monsters, imps and gods – belief in these creatures continues to dwell in human consciousness to this very day.



Yacuruna

The mighty Amazon River meanders across South America, churning its landmass, nourishing the densest jungles known to man. Over time, the region has grown infamous for swallowing entire expeditions whole, providing explorers with enough yarn to spin colourful tales about the horrors of its depths. But while headhunting tribes, piranha-infested waters, man-eating serpents and tropical diseases capture the imagination of the alien adventurer, the Amazonians themselves are watchful of the river with different intentions.

Derived from the Quechuan words Yacu (water) and Runa (man), the Yacuruna are believed to be mythical man-like creatures who covet the local women and are described as hairy, with their heads turned backwards and their feet deformed. However, the indigenous people of the Amazon liken them to gods, bearing testimony to their

magical powers of seduction. It is said that a Yacuruna can transform into a river dolphin, allowing it to seek out girls. It then transforms into an attractive man to lure its victims, even employing aphrodisiacs to aid it in its kidnapping scheme. Those who fall prey to the Yacuruna are smuggled away into their kingdoms – majestic, underwater cities consisting of palaces made from multi-coloured crystal and fish scales. Over time, the victims are permanently transformed into Yacuruna themselves, closely resembling their captors.

The Yacuruna spend the day sleeping in their cities, often located at the mouths of rivers and on lake beds. They are said to be extremely cautious, keeping one eye open at all times, even while in the deepest slumber. At night, they emerge into the open and roam the rainforest on the back of a black crocodile, wearing a serpent around their necks, searching for prey. It is not uncommon to find local fishermen who are adamant about getting home before dark, urging their daughters to stay indoors, for fear of abduction by a Yacuruna. But while most

keep their distance from these beings, there are those who seek them out. For it is said that the Yacuruna have healing abilities. Shamans beseech them to help them heal the sick. One can never be too careful with the Yacuruna, for it is only by appeasing them that one can ensure the safe return of a Yacuruna abductee.

Makara

India is a land teeming with gods and goddesses. In Hindu mythology alone, every aspect of nature finds representation, with water bodies being no exception. Lake and river goddesses hold an especially sacred place in Hindu belief, with the goddess Ganga being one of the most widely recognized. One of the largest rivers in existence and possibly the most sacred to the Hindus, it is no surprise that the Ganga (or the Ganges) is renowned the world over, drawing millions to its banks every year. But mighty as they may be, even divine beings require a vehicle to travel in; one that is befitting of their stature; and in this regard, goddess Ganga does not compromise.

Makara, which in Sanskrit translates to 'sea-dragon' or 'water-monster', are beings from Hindu mythology that serve as the celestial vehicles for the river goddesses Ganga, Narmada and also the sea god Varuna. Believed to be part terrestrial animal and part aquatic, they are often depicted as having the head of an elephant,

the horns of a deer, the legs of a lion, the jaws of a crocodile and the tail of a fish. However, there have been varying representations of Makara across South East Asia and speculation is rife about whether there existed several subspecies of the creature, or they were all mis-sightings of the same one.

Ancient scriptures describe Makara as being strong and ferocious, often entrusted with the guarding of a treasure or a throne room. They are also seen as symbols of chaos and fertility. Certain Indian fishing communities believe that while out at sea, if one is to encounter a Makara, then they must do their utmost to gratify it, for this will ensure a fruitful catch and a safe journey back home. Images of goddess Ganga from mythology show her seated on the back of a Makara, while holding its tongue and is representative of her power. She is believed to be bringing order from the chaos.



Glashtyn

There are some places on Earth that seem to be more conducive to the fantastic, and judging by its folklore, the Isle of Man is one of them. Right from its name, which can be traced back to the sea god Manannán – the original ruler of the island, to its history of witchcraft, Manx mythology is steeped in tales of goblins, spirits, fairies, imps and is traditionally rich with magical curiosities.

Originating from the Celtic Old Irish term *glaise*, which means stream, Glashtyn is an aquatic goblin, a shapeshifter that takes the form of a stallion when it becomes terrestrial. Appearing friendly at first, Glashtyn is known to lure unsuspecting men into riding it, trapping them on its back with its adhesive skin before returning to its home, taking its rider to a watery grave. However, when it comes to women, Glashtyns display immense curiosity and have been known to chase after them, even ripping off bits of their clothing. They sometimes even take on

the form of curly-haired, handsome men, in service of this curiosity. But what betrays their identity is their ears, which remain that of a horse.

Following in the goblins' long tradition of mischief-making, Glashtyns are known to be cunning, even mingling with ordinary livestock to appear docile. But while caution is generally advised around these beings, it is believed that their strong and muscular nature make them ideal farmhands and one is considered extremely fortunate to tame one. It is also said that the cries of a Glashtyn can be compared to the howling of wind and are indicative of a brewing storm. There are many who are thankful to these creatures for the warning, but there are also those who believe that it is these cries that cause the storm in the first place.

Kappa

One of the most striking aspects of Japanese culture, is its tradition of discipline. The orderliness of its people is something of a spectacle, garnering admirers from across the world. Meticulousness is something that is taken for granted in Japan, regardless of the task at hand, and this strongly extends to the maintenance of their cultural records. Considering that the Japanese also have an affinity for the supernatural, it is no surprise that their folklore is bursting with a vibrant, albeit neatly organized, variety of creatures.

Kappa is a water imp from traditional Japanese folklore, belonging to the *Yōkai* class of mythical beings. Getting its name from the words *kawa* (river) and *wappa* (child), it is said to be of humanoid form and resembles a small child. The skin of a Kappa is scaly and reptilian, with its colours ranging from green, to yellow, to blue. Webbed hands and feet make it an excellent swimmer and Kappa are known to reside in freshwater

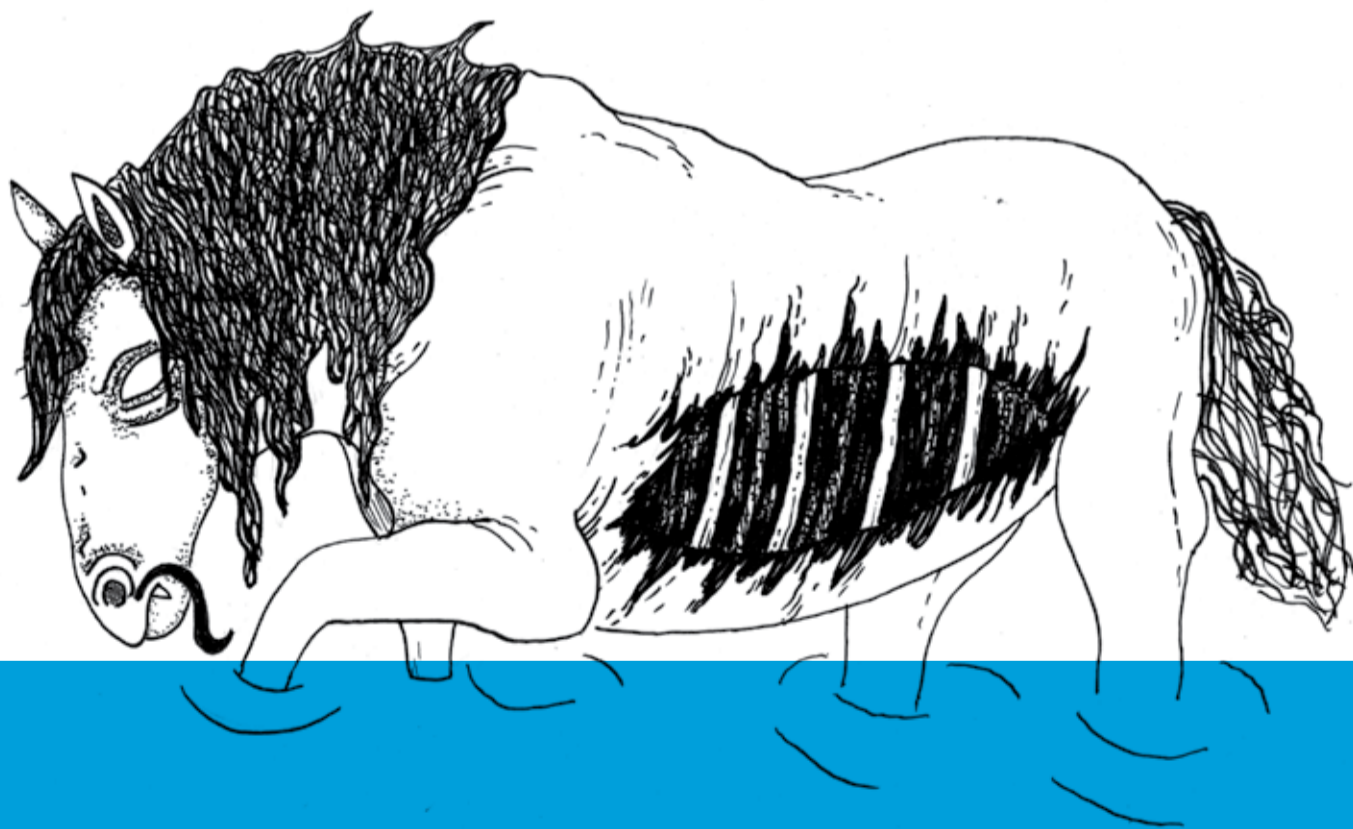



lakes and streams. While its image varies across Japan, with certain depictions giving it a beak, a plate or a shell, the most distinctive aspect of its appearance is also the most consistent. The top of a Kappa's head features a bald patch, containing a cavity that holds a small pool of water. When a Kappa comes ashore, this patch must be kept wet at all times, for it is the source of its power. If dry, the Kappa will rapidly weaken and waste away, eventually to die.

Kappas are generally known to be tricksters, mostly pulling harmless pranks on unsuspecting folk. They are said to be extremely curious about human beings, even going to the extent of learning Japanese. Considered to be experts in medicine, especially bone-setting, Kappa have been known to share their knowledge in exchange for cucumbers, their favourite food. But while a good portion of the folklore describes the Kappa as a friendly creature, there is

an equal amount of material to suggest the contrary. Kappas are known to be extremely fond of wrestling, often drowning their human challengers in the course of a match. They have also been known to kidnap people, drink their blood and feast on their flesh. Kunio Yanagita, one of Japan's foremost experts on its folklore has even written about women who have been accosted and impregnated by Kappa. On encountering one in the wild, if you are not confident to sumo-wrestle it, then you are left with only one course of action, to save yourself. Kappa are reputed to be obsessed with politeness and if one is to bow to them, then they will return the gesture, spill the pool of water from their heads and become frozen. The Kappa can only be revived if the cavity is replenished with water from the lake in which it lives. It is believed that if a person does this, then the Kappa is duty-bound to serve them for life.

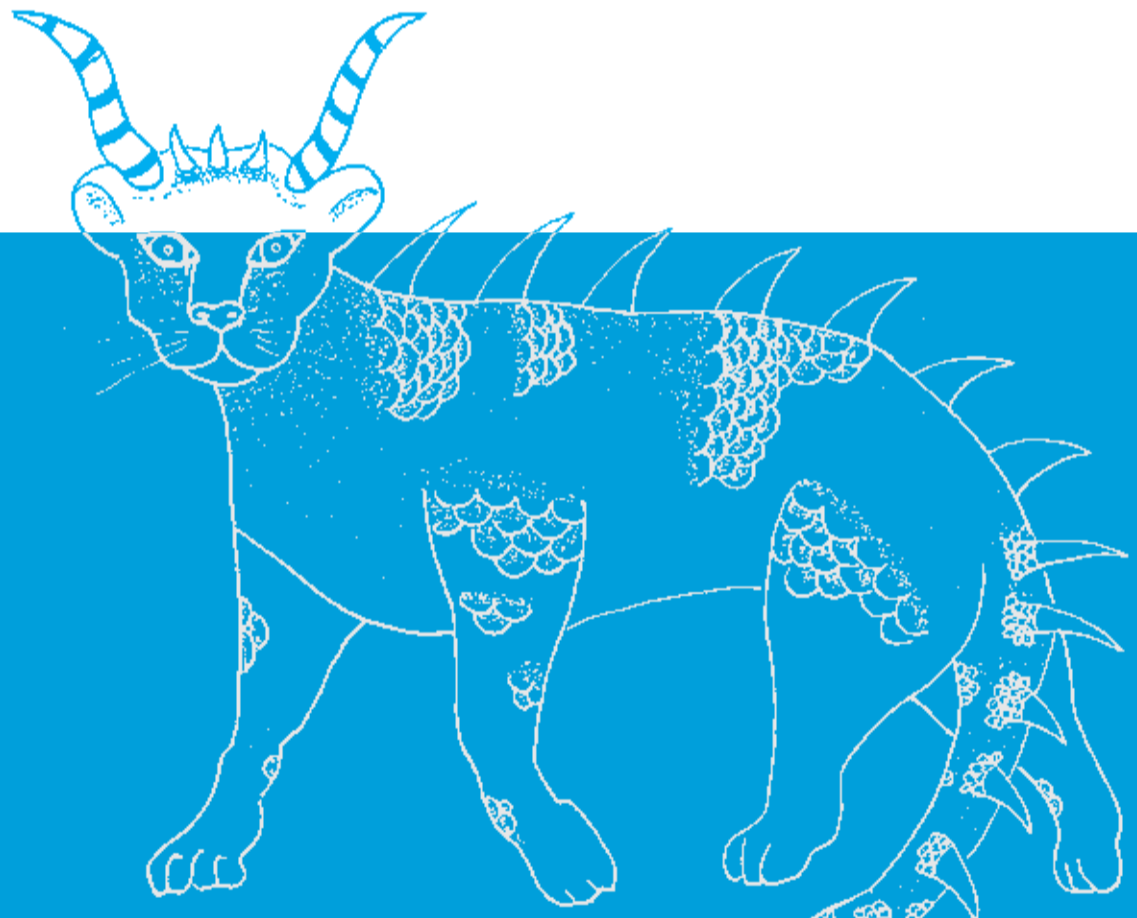

Mishipeshu

The indigenous Anishinaabe tribes of North America are known to have an intimate connection with Nature. It is said that they look upon their landscape as if it were a library, with its different formations (rocks, streams, trees, animals) being the books. Perhaps this is in some way responsible for the rich oral tradition that is found with most Native American tribes. However, since a large portion of their culture remains undocumented, the outside world has little knowledge of their folklore.

Mishipeshu, a mythical being from Anishinaabeg folklore, is more commonly known as the underwater panther. Known to possess immense power, it is depicted with the head, legs and body of a giant cat, but is

covered in fish scales, with jagged dagger-like spikes that run down its spine, to the tip of its extremely long tail. Mishipeshu is believed to be the master of all aquatic creatures, frequently calling upon water-snakes to do its bidding. Known to inhabit the Great Lakes area of North America, Mishipeshus are also believed to be guardians of vast amounts of copper, something that is feverishly sought after by Anishinaabeg medicine men. According to legend, they do not make any substantial use of this copper themselves, only giving bits and pieces to their cubs as playthings. While Mishipeshus have a reputation for being malevolent, there are some who believe that the proper appeasement will turn them into allies. This is

the reason for fishermen in the area to make an offering to the water, before setting out on a journey.

The roar of a Mishipeshu can be compared to the sound of rapids and they are said to live in the darkest depths of lakes. Apparently, every Mishipeshu ever born is said to live in opposition to another mythical creature, the Thunderbird. Thunderbirds are considered to be masters of the sky and it is believed that these two creatures have been locked in eternal conflict. With both of them possessing the ability to influence the weather, their battles are said to cause the most devastating storms known to man.

Aurora Credits

Aurora is commissioned by FACT, in partnership with Liverpool City Council, Invisible Flock and Dingle 2000. Supported using public funding by the National Lottery through Arts Council England, and British Council.

Arrival City, is supported by Goethe-Institut and the Summer Social is part of Festival 31.

Aurora is made by Invisible Flock in collaboration with Miebi Sikoki and Rudi Nurhandi (Digital Nativ, Indonesia), Babitha George & Romit Raj (Quicksand, India), Abshar Platisza (Indonesia), Azusa Ono (Japan/UK), Bagus Pandega (Indonesia), Etza Meisyara (Indonesia), James Hamilton (UK) and Simon Fletcher (UK).

This publication was conceptualised by Quicksand and designed in collaboration with Studio Carrom.

Quicksand is a design strategy and innovation consultancy headquartered in India, and working in emerging markets.

Studio Carrom is an interdisciplinary design studio based in London and Bangalore.

Do get in touch with us to share any thoughts, questions or responses – flock@invisibleflock.com

fact.co.uk/aurora

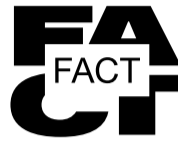
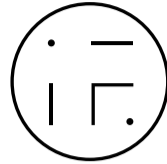

Supported using public funding by
**ARTS COUNCIL
ENGLAND**

